

### TECHNICAL CHARACTERISTICS

- > Length: 1800 mm
- > Seat depth: 404 mm
- > Seat height: 453 mm
- > Frame: high quality cast iron, metallic grey or black finish or black finish
- > Recycled plastic\* seat and backrest, thickness: 40 mm, slat width: 120 mm
- > Seat slats reinforced with a 25 x 6 mm galvanised steel cradle



Code 209680  
with frame in black finish

### INSTALLATION

- > On base plates
- > Flat packed for self assembly (all wooden slats are pre-drilled for easy assembly)

### PRODUCT CODE

Mora steel and recycled plastic seat	209680
--------------------------------------	--------



Code 209680  
with frame in metallic grey finish

### DRAWING

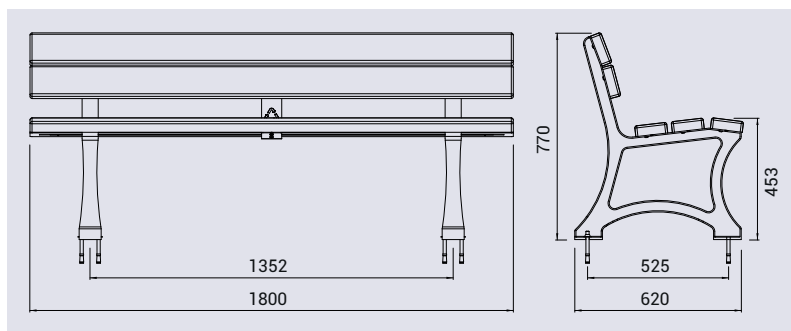

### FINISH PAINTED

- > Cast iron, zinc primed & painted in metallic grey or black finish
- > Brown recycled plastic slat

