

MODULO bicycle shelter

>> On base plates <<
>> New deep: 3400 mm <<



TECHNICAL CHARACTERISTICS

- > Dimensions: 2500 mm wide x 2250 mm high
- > 2 depths: 2000 or 3400 mm
- > Structure: steel tubes 70 x 70 mm
- > Roof: anodised aluminum profiles with cross members in 40 x 40 mm steel tube and anti-UV-treated 10 mm cellular polycarbonate panels
- > Extension: extension module, 2500 mm wide

INSTALLATION

- > Installation concreted directly into ground or on base plates, height adjustable legs (80 mm)

OPTIONS

- > Rear and side cladding: 5 mm safety glass
- > Motorbike locking rail
- > Side wind protectors (pair)
- > Bike racks and stands
- > *The Modulo shelter is available with HPL cladding, consult us*



Code 529451



Code 529190 + 209147

PRODUCT CODES

	Concreted directly into ground		On base plates	
	Depth 2000 mm	Depth 3400 mm	Depth 2000 mm	Depth 3400 mm
Basic bike shelter without cladding	529173	529193	599173	599193
Extension bike shelter without cladding	529174	529194	599174	599194
"All-in-one" basic bike shelter - 2500 mm wide (basic + side cladding + rear cladding)	529170	529190	599170	599190
"All-in-one" bike shelter - 5000 mm wide (basic + extension + rear cladding + side cladding)	529171	529191	599171	599191
"All-in-one" extension bike shelter - 2500 mm wide (extension + side cladding)	529172	529192	599172	599192
Options				
Side cladding (1 side)	529175			
Rear cladding - basic bike shelter	529176		599176	
Rear cladding - extension bike shelter	529177		599177	
Motorbike locking rail	209147			
Side wind protectors (pair)	529679			

DRAWING

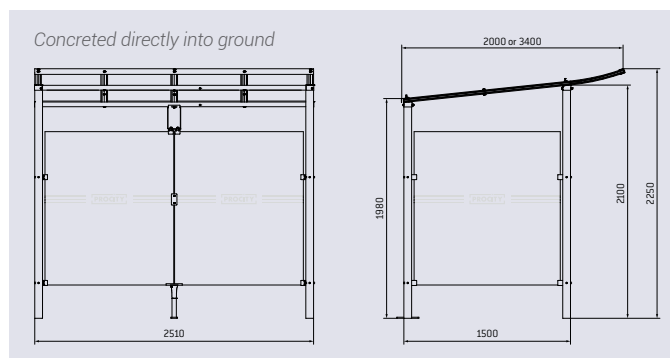

FINISH PAINTED

- > Galvanised steel painted in our colours

